

# BN-TYPE

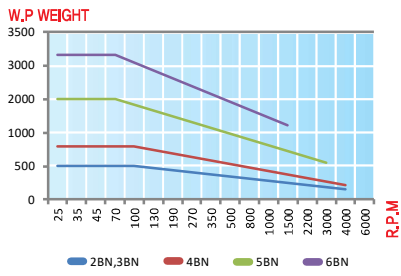

## FEATURES ;

- Accuracy guaranteed to 0,003mm TIR (0,0001").
- Excellent for engine lathes and CNC lathes.
- Heat-treated point to HRC 60±2.
- High performance lip seal and deflected shaft design protects bearing space(Double Angular Contact bearing) from invasion by dust and coolant.
- Heat-treated body for extra strength, rigidity and long life.



BN type technical data

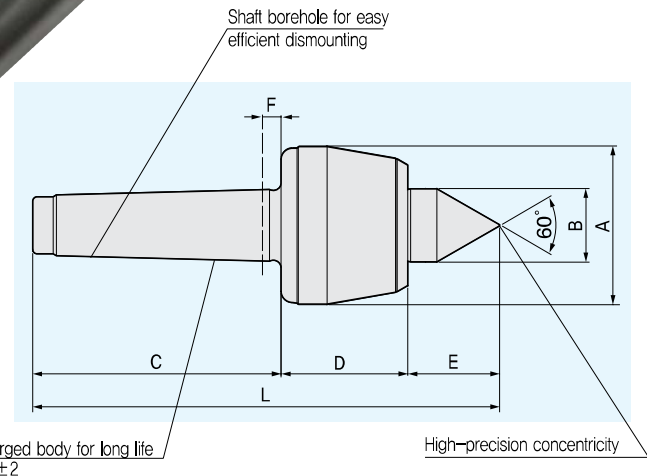

## Dimension

01	1	0	0	MT	Unit : mm, kg							
MODEL	MT	A	B	C	D	E	F	L	Workpiece Weight	Max. R.P.M	Weight	Max. Run Out
011002	2	50	25	68	43,5	29,5	6	141	500	5,000	0,7	0,003
011003	3	50	25	85	43,5	29,5	6	158	500	5,000	0,8	0,003
011004	4	69	32	108	55	40	8	203	800	3,800	1,85	0,003
011005	5	88	40	136	70	50,5	8	256,3	2,000	3,000	4,2	0,003
011006	6	105	50	189	81,5	57,5	10	328	3,500	2,800	8,7	0,005