

# BN-TYPE

## FEATURES ;

- Accuracy guaranteed to 0,003mm TIR (0,0001").
- Excellent for engine lathes and CNC lathes.
- Heat-treated point to HRC 60±2.
- High performance lip seal and deflected shaft design protects bearing space(Double Angular Contact bearing) from invasion by dust and coolant.
- Heat-treated body for extra strength, rigidity and long life.

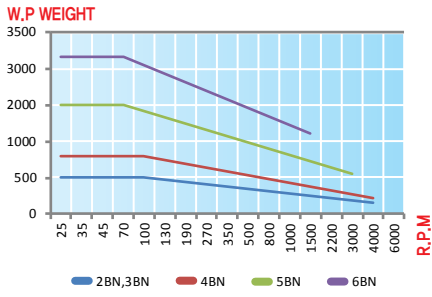

BN type technical data

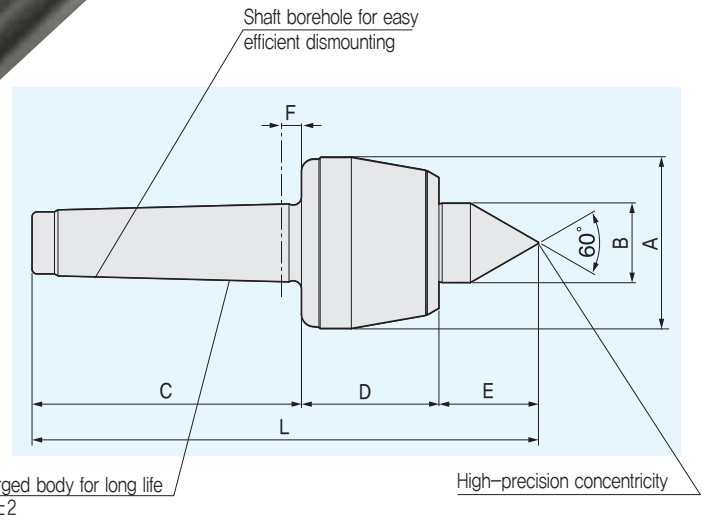

## Dimension

01	1	0	0	MT	Unit : mm, kg							
MODEL	MT	A	B	C	D	E	F	L	W.P Weight	Max, R.P.M	Weight	Max, Run Out
011002	2	50	25	68	43.5	29.5	6	141	500	5,000	0.7	0,003
011003	3	50	25	85	43.5	29.5	6	158	500	5,000	0.8	0,003
011004	4	69	32	108	55	40	8	203	800	3,800	1.85	0,003
011005	5	88	40	136	70	50.5	8	256.3	2,000	3,000	4.2	0,003
011006	6	105	50	189	81.5	57.5	10	328	3,500	2,800	8.7	0,005