

BNI-TYPE

FEATURES ;

- Accuracy for center inner diameter guaranteed to 0.003.
- Accuracy after point locking guaranteed to 0.005.
- Excellent for engine lathes and CNC lathes.
- Heat-treated point to HRc 60±2.
- The interchangeable center points are standard point, 75° point, 90° point, extra-long point, pipe point, and female point.
- Because of the insert centers, the admissible workpiece weight is reduced.

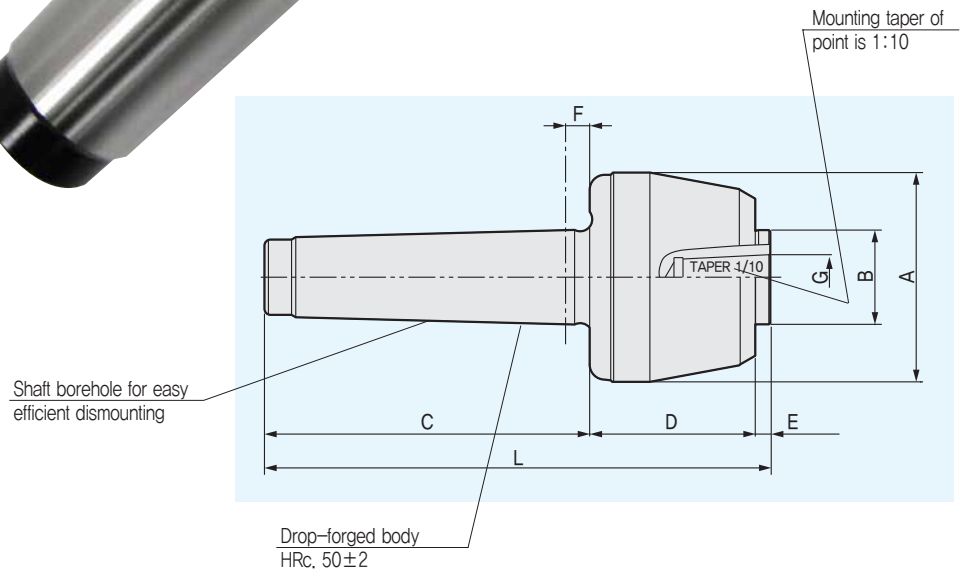

Dimension

Unit : mm, kg

05	1	0	0	MT									
MODEL	MT	A	B	C	D	E	F	G	L	W.P Weight	Max, R.P.M	Weight	Max, Run Out
051002	2	50	25	68	43.5	5	6	12	116.5	80	5,000	0.6	0.005
051003	3	50	25	85	43.5	5	6	12	133.5	150	5,000	0.8	0.005
051004	4	69	32	108	55	5	8	15	168	250	3,800	1.7	0.005
051005	5	88	40	136	70	6	8	22	212	650	3,000	3.9	0.005

BNI-POINT

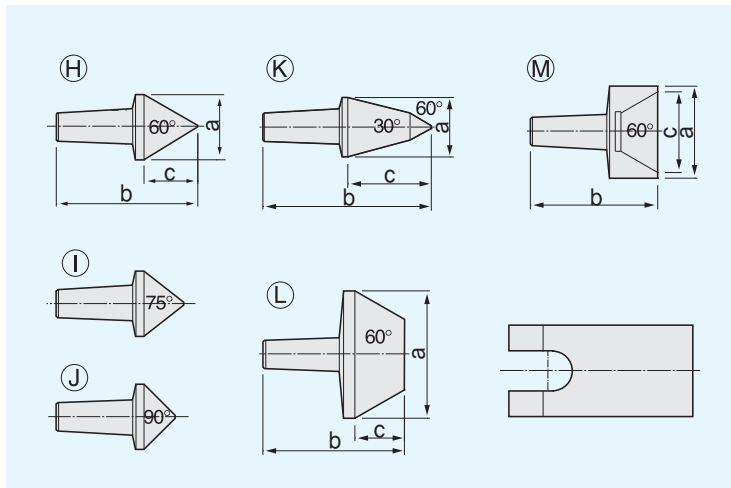

INTER CHANGEABLE POINTS LIVE CENTERS

Dimension

Unit : mm, kg

MODEL	MT		H	I	J	K	L	M
051002	2	a	24	24	24	18	45	22
		b	51.5	46.5	43	54	51	40
		c	20	15	11.5	25	17.5	18
051003	3	a	24	24	24	18	45	22
		b	51.5	46.5	43	54	51	40
		c	20	15	11.5	25	17.5	18
051004	4	a	28	28	28	26	55	40
		b	61.5	55.5	51.5	73	61.5	55
		c	23.5	17.5	13.5	36	21.5	35
051005	5	a	38	38	38	32	70	52
		b	78	70	64	90	74	65
		c	32	24	18.5	46	26	45