

BNL30A-TYPE

FEATURES ;

- Accuracy guaranteed to 0.003mm TIR (0.0001").
- Excellent for engine lathes and CNC lathes.
- Heat-treated point to HRC 60±2.
- High performance lip seal and deflected shaft design protects bearing space(Double Angular Contact bearing) from invasion by dust and coolant.
- Heat-treated body for extra strength, rigidity and long life.

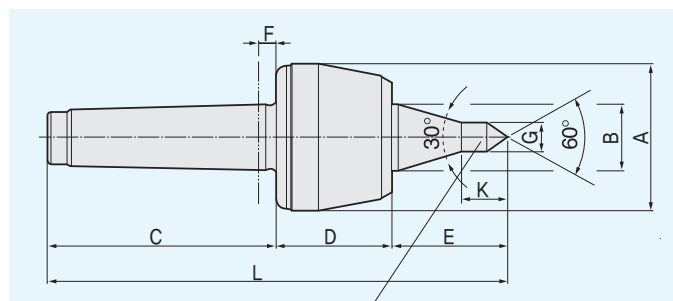
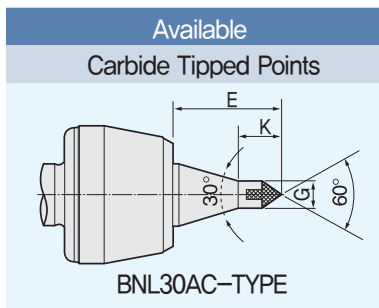

Elongated center point is specially shaped for improved tool clearance(Diagram)

Dimension

01	5	0	0	MT											Unit : mm, kg	
MODEL	MT	A	B	C	D	E	F	G	K	L	W.P Weight	Max, R.P.M	Weight	Max, Run Out		
015002	2	50	25	68	43.5	50	6	10	19	161.5	500	5,000	0.7	0.003		
015003	3	50	25	85	43.5	50	6	10	19	178.5	500	5,000	0.8	0.003		
015004	4	69	32	108	55	63.5	8	12.5	23.5	226.5	500	3,800	1.9	0.003		
015005	5	88	40	136	70	80	8	12.5	23.5	286	1,500	3,000	4.4	0.003		
015006	6	105	50	189	81.5	105	10	14	30	375.5	2,500	2,800	8.7	0.005		