

BP80-TYPE

FEATURES ;

- Accuracy guaranteed to 0,003mm TIR (0,0001").
- Excellent for heavy duty lathe applications.
- The interior houses a combination of taper roller bearing, thrust bearing, and high-precision radial ball bearing.
- The design prevents ingress of coolant and chips.
- For pipe work, tube work, and parts with extra-large center holes.

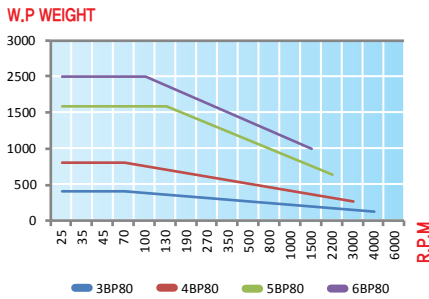

BP80 type technical data

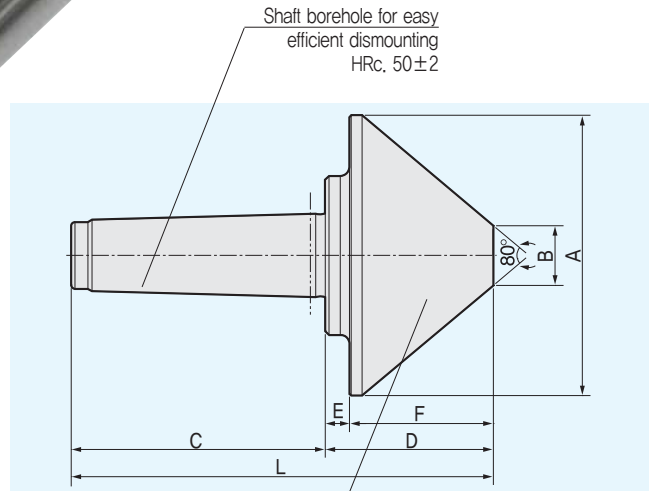

Large size head is available
made of wear-resistant tool steel
drop-forged HRc. 60±2

Dimension

08	3	0	0	MT								
MODEL	MT	A	B	C	D	E	F	L	W.P Weight	Max, R.P.M	Weight	Max, Run Out
083003	3	95	20	85	60	10	50	145	400	4,000	2.4	0.003
083004	4	125	29	108	77	13	64	185	800	3,000	3.9	0.003
083005	5	150	32	136	90	13	77	226	1,600	2,000	6.9	0.003
083006	6	200	38	189	120	15	105	309	2,500	1,500	17	0.005

Unit : mm, kg